



CCR 364, 1 Torr F.S., DN 16 ISO-KF



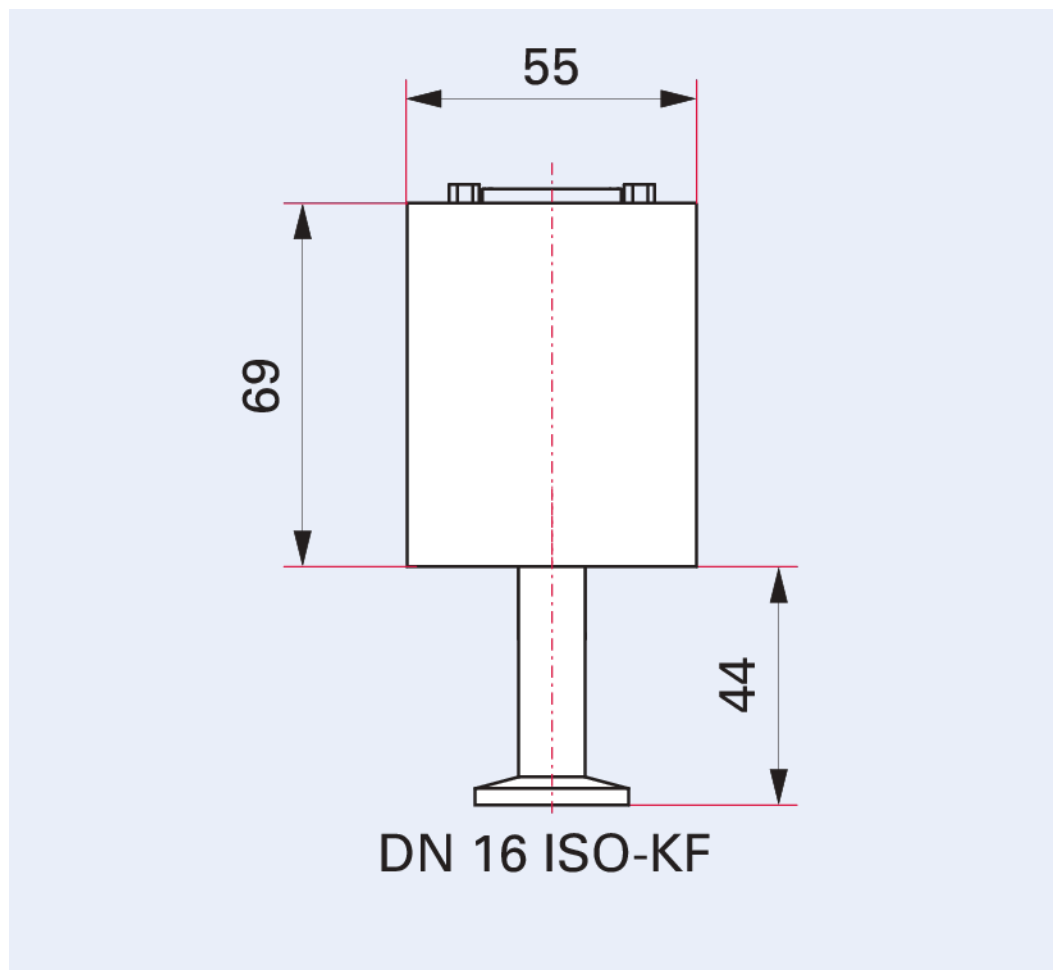

Illustration only

CCR 364, 1 Torr F.S., DN 16 ISO-KF

- Measurement range from $1.33 \cdot 10^{-4}$ – 1.33 hPa
- Accuracy: 0.2 % of measurement
- Supply voltage: 14 – 30 V
- Output signal: 0 – 10 V
- Ceramic technology sensor
- No memory effects
- Precise temperature compensation
- Excellent zero stability
- Output signal an connector compatible with MKS Baratron
- Calibration test report included in delivery

Dimensions



| Technical Data | CCR 364, 1 Torr F.S., DN 16 ISO-KF |
|-----------------------------------|---|
| Output signal: Measuring range | 0 – 10 V |
| Measuring range | $1.33 \cdot 10^{-4} - 1.33 \cdot 10^0$ hPa |
| Materials in contact with media | Ceramic (Al ₂ O ₃ = 99.5 %) Stainless steel (AISI 316L) |
| Flange, material | Stainless steel 1.4404 (AISI 316L) |
| Bakeout temperature at the flange | ≤110 °C |
| Temperature effect: on zero point | 0,015 % F.S./°C |
| Temperature effect: on range | 0.01% of measured value/ °C |
| Anode | 130727 |
| Ambient temperature | 5 – 50 °C |
| Temperature: Storage, max | +65 °C |
| Temperature: Storage, min | -40 °C |
| Measuring accuracy | 0.2 % (of measured value) |
| Measuring method | Capacitive |
| Input voltage(s) | 14 – 30 V DC |
| Volume | ≤3.6 cm ³ |
| Bakeout temperature at the flange | ≤110 °C ≤230 °F ≤383.15 K |
| Output signal: Minimum load | 10 kΩ |
| Pressure max. | $2 \cdot 10^3$ hPa $1.5 \cdot 10^3$ Torr $2 \cdot 10^3$ mbar |
| Full scale | 1.33 hPa 0.998 Torr 1.33 mbar |
| Weight | 0.37 kg 0.82 lb |
| Resolution | 0.003 % F.S. |
| Pressure max. | $2 \cdot 10^3$ hPa |
| Response time | 30 ms |
| Power consumption max. | 1 W |
| Output signal: Minimum load | 10 kΩ |
| Connection flange | DN 16 ISO-KF |
| Weight | 0.37 kg |

| Order number | CCR 364, 1 Torr F.S., DN 16 ISO-KF |
|------------------------------------|---|
| CCR 364, 1 Torr F.S., DN 16 ISO-KF | 2000006233 |



伯东企业（上海）有限公司
HAKUTO ENTERPRISES (SHANGHAI) LTD.
TEL: (86) 21-5046 3511

上海伯东 -- 您理想的真空合作伙伴！

伯东公司成立于 1953 年，外企上市企业，全球范围内有一千七百名员工，集团年营业额约为 100亿人民币。

伯东公司在国内主要城市：上海，北京，苏州，广州，深圳，成都及厦门设有营业据点。

上海伯东真空产品事业部已累计为超过 10,000 家企业提供真空服务

我们致力于追求高品质的服务，为您提供一流的服务及一流产品：

品质保障：国际知名品牌指定授权代理商，所有产品及部件保证 100% 原厂原装进口

现货交期快：部分产品有现货，下单立即发货（现货数量有限，实际情况请联系销售工程师）

卓越维修能力：伯东工程师拥有10年以上维修经验，且受国外专业培训，拥有完全的拆解，维修，校正能力。

完美服务质量：原装进口检测设备全方位寻找问题症结及全方面的性能测试，确保完美的服务质量



伯东企业（上海）有限公司 销售及售后服务中心

上海浦东新区新金桥路1888号36号楼7楼702室

电话：+86-21-5046-3511 / 139-1883-7267

传真：+86-21-5046-1490

官网：<http://www.hakuto-vacuum.cn>

