

HiCube 700, DN 160 CF- F, ACP 28

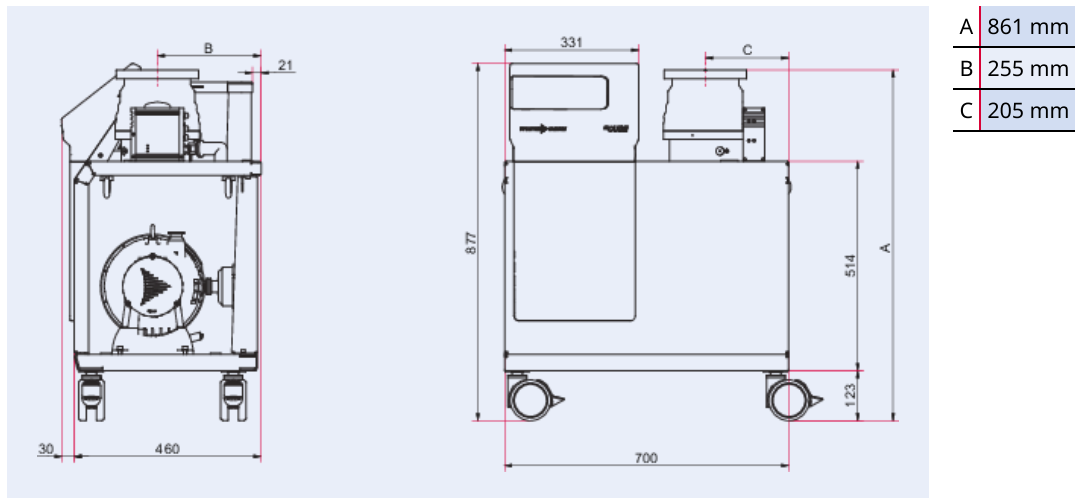

Illustration only

HiCube 700, DN 160 CF-F, ACP 28

- Compact series of pumping stations for all high vacuum applications
- Simple operation with touch display
- Remote control via web server available
- Reliable and robust

Dimensions



Technical Data	HiCube 700, DN 160 CF-F, ACP 28
Cooling method	Air (Forced convection)
Pumping speed backing pump	50 Hz: 27 m ³ /h
Pumping speed for N ₂	685 l/s
Motor for region	Worldwide
Type	Turbo pumping station
Turbopump	HiPace 700
Ambient temperature	12 – 35 °C
Temperature: Storage, max	55 °C
Temperature: Storage, min	-10 °C
Rated power at max. rotation speed	1,085 W
Input voltage(s)	100 – 120 / 200 – 240 V AC (±10 %), 50/60 Hz
Emission sound pressure level (EN ISO 2151)	≤50 dB(A)
Pumping speed for N ₂	685 l/s
Weight	96.5 kg 212.75 lb
Backing pump	ACP 28
Connection flange	DN 160 CF-F
Fore-vacuum safety valve	Yes
Weight	96.5 kg
Connection flange (in)	DN 160 CF-F
Connection flange (out)	DN 25 ISO-KF
Order number	HiCube 700, DN 160 CF-F, ACP 28
HiCube 700, DN 160 CF-F, ACP 28	2000281280



伯东企业（上海）有限公司
HAKUTO ENTERPRISES (SHANGHAI) LTD.
TEL: (86) 21-5046 3511

上海伯东 -- 您理想的真空合作伙伴！

伯东公司成立于 1953 年，外企上市企业，全球范围内有一千七百名员工，集团年营业额约为 100亿人民币。

伯东公司在国内主要城市：上海，北京，苏州，广州，深圳，成都及厦门设有营业据点。

上海伯东真空产品事业部已累计为超过 10,000 家企业提供真空服务

我们致力于追求高品质的服务，为您提供一流的服务及一流产品：

品质保障：国际知名品牌指定授权代理商，所有产品及部件保证 100% 原厂原装进口

现货交期快：部分产品有现货，下单立即发货（现货数量有限，实际情况请联系销售工程师）

卓越维修能力：伯东工程师拥有10年以上维修经验，且受国外专业培训，拥有完全的拆解，维修，校正能力。

完美服务质量：原装进口检测设备全方位寻找问题症结及全方面的性能测试，确保完美的服务质量



伯东企业（上海）有限公司 销售及售后服务中心

上海浦东新区新金桥路1888号36号楼7楼702室

电话：+86-21-5046-3511 / 139-1883-7267

传真：+86-21-5046-1490

官网：<http://www.hakuto-vacuum.cn>

