

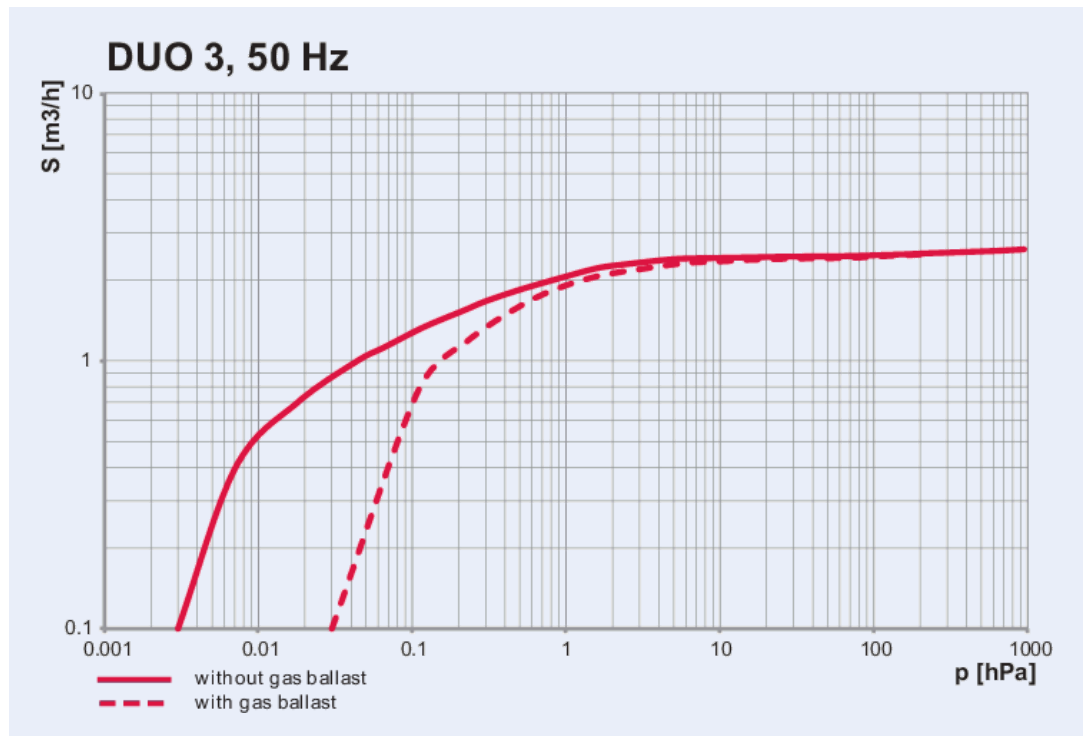

Illustration only

DuoVane 3, 1-phase motor, 100 – 115/200 – 230 V, 50/60 Hz

- Dual-stage, high-performance rotary vane pump with a pumping speed of 2.5 m³/h at 50 Hz / 2.9 m³/h at 60 Hz
- With 1-phase motor IE 2, with C14 plug inside terminal box
- Integrated gas ballast and safety valve
- OME oil return device is included with the pump
- For all low and medium vacuum applications
- Special feature: Various motor voltages for worldwide employment
- Other motor voltages available on request

Characteristics



Dimensions

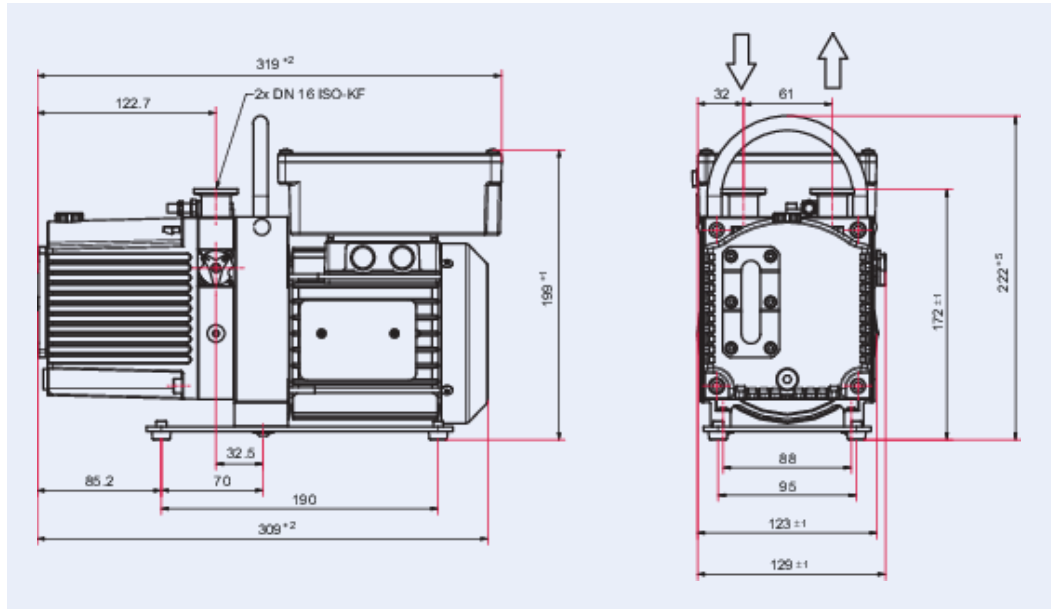

Technical Data	DuoVane 3, 1-phase motor, 100 – 115/200 – 230 V, 50/60 Hz
Gas ballast	Yes
Operating fluid	P3
Cooling method	Air (Forced convection)
Motor type	1-phase motor
Recommended on-site electric fuse protection	6 A
Ambient temperature	12 – 40 °C
Temperature: Storage, max	55 °C
Temperature: Storage, min	-25 °C
Input voltage(s)	100 – 115 / 200 – 230 V AC (±5 %), 50/60 Hz
Ultimate pressure with gas ballast	3 · 10 ⁻² hPa 2.25 · 10 ⁻² Torr 3 · 10 ⁻² mbar
Gas ballast pressure	1,500 hPa 1,125 Torr 1,500 mbar
Leakage rate safety valve	1 · 10 ⁻⁵ Pa m ³ /s 7.5 · 10 ⁻⁵ Torr l/s 1 · 10 ⁻⁴ mbar l/s
Continuous gas input temperature, max.	40 °C 104 °F 313.2 K
Exhaust pressure, max.	1,500 hPa 1,125 Torr 1,500 mbar
Gas ballast flow	540 l/h
Water vapor tolerance at 60 Hz	80 hPa 60 Torr 80 mbar
Water vapor tolerance at 50 Hz	65 hPa 48.8 Torr 65 mbar
Rotation speed at 60 Hz	3,600 rpm 3,600 min ⁻¹
Rotation speed at 50 Hz	3,000 rpm 3,000 min ⁻¹
Pumping speed at 60 Hz	2.9 m ³ /h 1.71 cfm 48.33 l/min
Pumping speed at 50 Hz	2.5 m ³ /h 1.4715 cfm 41.6675 l/min
Switch	Yes
Exhaust pressure, max.	1,500 hPa
Gas ballast flow	540 l/h
Gas ballast pressure	1,500 hPa
Motor protection	Bimetal
Water vapor capacity 60 Hz	175 g/h
Water vapor capacity 50 Hz	115 g/h
Mains cable	No, C14-plug inside the terminal box
Rated power 50 Hz	0.15 kW
Rated power 60 Hz	0.18 kW
Final pressure with gas ballast	3 · 10 ⁻² hPa
Dimensions (L x W x H)	319 x 130 x 199 mm
Number of pumping stages	Two stage

Rotation speed at 50 Hz	3,000 rpm
Operating fluid amount	0.4 l
Exhaust pressure, min.	Atmospheric pressure
Weight	10.5 kg
Pumping speed at 60 Hz	2.9 m ³ /h
Pumping speed at 50 Hz	2.5 m ³ /h
Connection flange (in)	DN 16 ISO-KF
Connection flange (out)	DN 16 ISO-KF

Order number	DuoVane 3, 1-phase motor, 100 - 115/200 - 230 V, 50/60 Hz
DuoVane 3, 1-phase motor, 100 - 115/200 - 230 V, 50/60 Hz	PK D570 010 C0 B



伯东企业（上海）有限公司
HAKUTO ENTERPRISES (SHANGHAI) LTD.
TEL: (86) 21-5046 3511

上海伯东 -- 您理想的真空合作伙伴！

伯东公司成立于 1953 年，外企上市企业，全球范围内有一千七百名员工，集团年营业额约为 100亿人民币。

伯东公司在国内主要城市：上海，北京，苏州，广州，深圳，成都及厦门设有营业据点。

上海伯东真空产品事业部已累计为超过 10,000 家企业提供真空服务

我们致力于追求高品质的服务，为您提供一流的服务及一流产品：

品质保障：国际知名品牌指定授权代理商，所有产品及部件保证 100% 原厂原装进口

现货交期快：部分产品有现货，下单立即发货（现货数量有限，实际情况请联系销售工程师）

卓越维修能力：伯东工程师拥有10年以上维修经验，且受国外专业培训，拥有完全的拆解，维修，校正能力。

完美服务质量：原装进口检测设备全方位寻找问题症结及全方面的性能测试，确保完美的服务质量



伯东企业（上海）有限公司 销售及售后服务中心

上海浦东新区新金桥路1888号36号楼7楼702室

电话：+86-21-5046-3511 / 139-1883-7267

传真：+86-21-5046-1490

官网：<http://www.hakuto-vacuum.cn>

