



**DuoVane 12, 3-phase
motor, 200-
220/240/380-415 V,
50 Hz | 200-
220/280/380-480 V,
60 Hz, Bimetal**

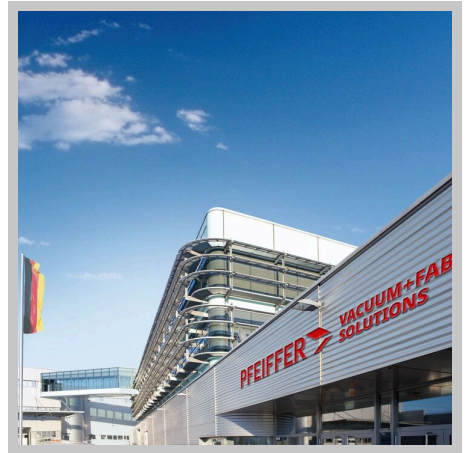

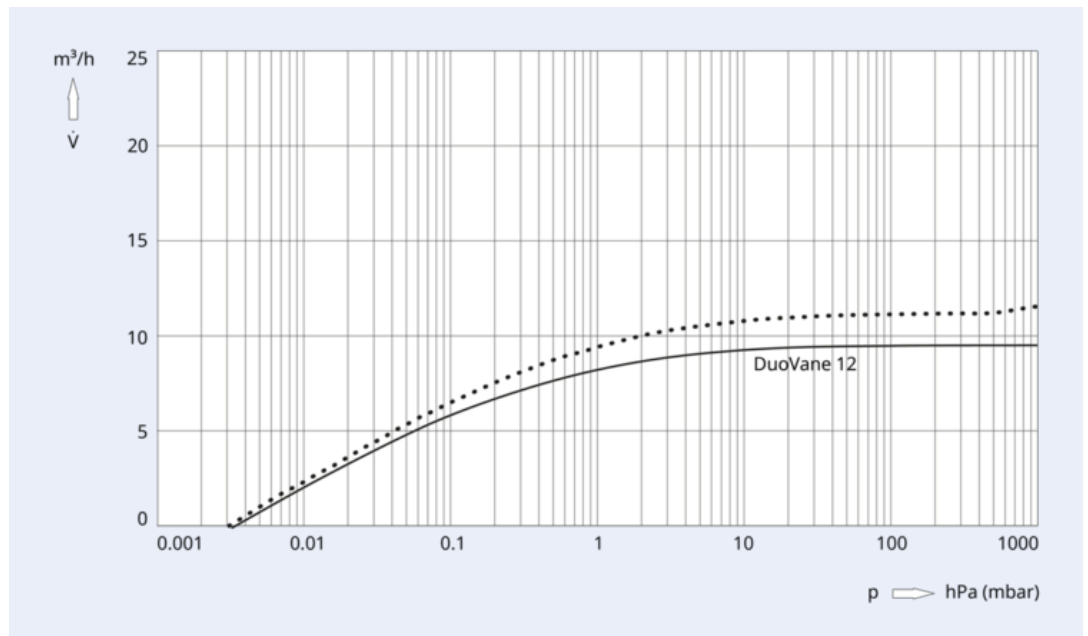

Illustration only

DuoVane 12, 3-phase motor, 200–220/240/380–415 V, 50 Hz | 200–220/280/380–480 V, 60 Hz, Bimetal

- Dual-stage, high-performance rotary vane pump with a pumping speed up to 12 m³/h
- With 3-phase motor
- With temperature sensor (Bimetal) for optimum motor protection
- Integrated gas ballast and HV safety valve
- For all low and medium vacuum applications
- Special feature: Various motor voltages for worldwide employment

Characteristics



Dimensions

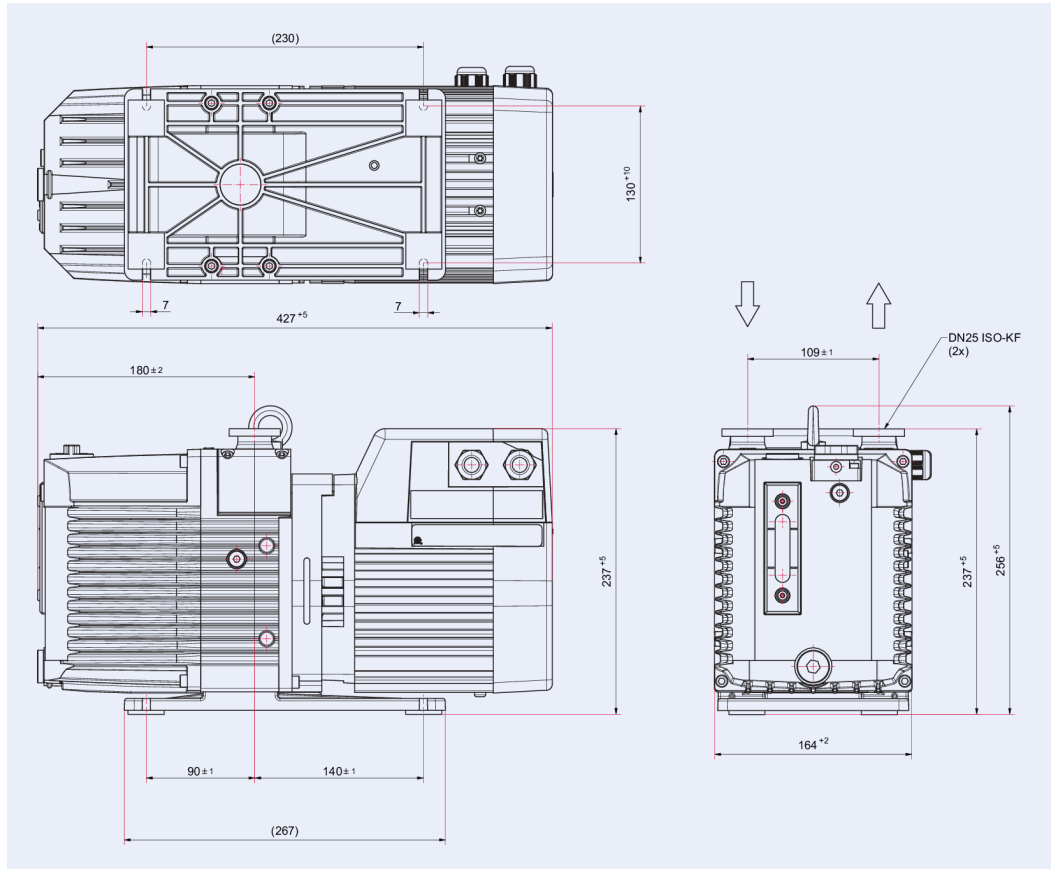

Technical Data	DuoVane 12, 3-phase motor, 200-220/240/380-415 V, 50 Hz 200-220/280/380-480 V, 60 Hz, Bimetal
Gas ballast	Yes
Operating fluid	P3
Cooling method	Air (Forced convection)
Motor type	3-phase motor
Vacuum range min	$1 \cdot 10^{-2}$ hPa
Vacuum range max	$3 \cdot 10^{-3}$ hPa
Ambient temperature	12 – 40 °C
Temperature: Storage, max	55 °C
Temperature: Storage, min	-25 °C
Certification	CE
Input voltage(s)	200 – 220 / 240 / 380 – 415 V AC, 50 Hz 200 – 220 / 280 / 380 – 480 V AC ($\pm 5\%$), 60 Hz
Ultimate pressure with gas ballast	$1 \cdot 10^{-2}$ hPa $7.5 \cdot 10^{-3}$ Torr $1 \cdot 10^{-2}$ mbar
Leakage rate safety valve	$1 \cdot 10^{-5}$ Pa m ³ /s $7.5 \cdot 10^{-5}$ Torr l/s $1 \cdot 10^{-4}$ mbar l/s
Continuous gas input temperature, max.	40 °C 104 °F 313.2 K
Exhaust pressure, max.	1,500 hPa 1,125 Torr 1,500 mbar
Operating altitude, max.	2,000 m
Continuous inlet pressure, max.	50 hPa 37.5 Torr 50 mbar
Rotation speed at 60 Hz	1,800 rpm 1,800 min ⁻¹
Rotation speed at 50 Hz	1,500 rpm 1,500 min ⁻¹
Pumping speed at 60 Hz	11.8 m ³ /h 6.95 cfm 196.67 l/min
Pumping speed at 50 Hz	9.5 m ³ /h 5.5917 cfm 158.3365 l/min
Switch	No
Exhaust pressure, max.	1,500 hPa
Motor protection	Bimetal
Mains cable	No
Rated power 50 Hz	0.55 kW
Rated power 60 Hz	0.66 kW
Final pressure with gas ballast	$1 \cdot 10^{-2}$ hPa
Dimensions (L x W x H)	432 x 166 x 239 mm
Continuous inlet pressure, max.	50 hPa
Number of pumping stages	Two stage
Connection flange	DN 25 ISO-KF / DN 25 ISO-KF
Rotation speed at 60 Hz	1,800 rpm

Rotation speed at 50 Hz	1,500 rpm
Operating fluid amount	1.2 l
Exhaust pressure, min.	Atmospheric pressure
Weight	27 kg
Pumping speed at 60 Hz	11.8 m ³ /h
Pumping speed at 50 Hz	9.5 m ³ /h
Connection flange (in)	DN 25 ISO-KF
Connection flange (out)	DN 25 ISO-KF

Order number	DuoVane 12, 3-phase motor, 200–220/240/380–415 V, 50 Hz 200-220/280/380-480 V, 60 Hz, Bimetal
DuoVane 12, 3-phase motor, 200–220/240/380–415 V, 50 Hz 200-220/280/380-480 V, 60 Hz, Bimetal	PK D920 020 14

Accessories	DuoVane 12, 3-phase motor, 200–220/240/380–415 V, 50 Hz 200-220/280/380-480 V, 60 Hz, Bimetal
Maintenance kit 1 for DuoVane 5 - 20	PK E31 200 -T
Maintenance kit 2 for DuoVane 10	PK E31 212 -T
Service Kit 3 for DuoVane 12	PK E32 202 -T
Valves and springs for DuoVane 10	PK E34 202 -T
Diaphragm HV valve for DuoVane 5 - 20	PK E34 210 -T
Rotary shaft seal for DuoVane 5 - 20	PK E36 200 -T
Vane DuoVane 12	PK E38 202 -T
P3 operating fluids for DuoVane 6 – 22	PK E39 200 -T
Gas ballast valve for DuoVane 5 - 20	PK E39 205 -T
Sight glass for DuoVane 5 - 20	PK E39 206 -T
Seal kit for DuoVane 10	PK E30 202 -T



伯东企业（上海）有限公司
HAKUTO ENTERPRISES (SHANGHAI) LTD.
TEL: (86) 21-5046 3511

上海伯东 -- 您理想的真空合作伙伴！

伯东公司成立于 1953 年，外企上市企业，全球范围内有一千七百名员工，集团年营业额约为 100亿人民币。

伯东公司在国内主要城市：上海，北京，苏州，广州，深圳，成都及厦门设有营业据点。

上海伯东真空产品事业部已累计为超过 10,000 家企业提供真空服务

我们致力于追求高品质的服务，为您提供一流的服务及一流产品：

品质保障：国际知名品牌指定授权代理商，所有产品及部件保证 100% 原厂原装进口

现货交期快：部分产品有现货，下单立即发货（现货数量有限，实际情况请联系销售工程师）

卓越维修能力：伯东工程师拥有10年以上维修经验，且受国外专业培训，拥有完全的拆解，维修，校正能力。

完美服务质量：原装进口检测设备全方位寻找问题症结及全方面的性能测试，确保完美的服务质量



伯东企业（上海）有限公司 销售及售后服务中心

上海浦东新区新金桥路1888号36号楼7楼702室

电话：+86-21-5046-3511 / 139-1883-7267

传真：+86-21-5046-1490

官网：<http://www.hakuto-vacuum.cn>

